

E-LED B High Mast Lights

400W 480W

► FEATURES & BENEFITS

- IP65 rated LED floodlight
- Rotatable modules offering maximum customisation
- Heavy duty stirrup mounting bracket
- Multiple optics available
- Can be installed as a floodlight or high bay
- With illumination equivalent to 800 watt and 1000W metal halide fixtures you'll enjoy an "instant-on, flicker-free" cold start, and industry-leading 155-160Lm/W.
- Protractor scale for easier aiming
- 50,000-hour operating life means years of maintenance free operation.
- Unique design extracts heat from the light source, thereby extending component life and ultimately prolonging the useful life of the fixture.
- Lightweight design provides easy retrofitting of existing HID installations, along with quick mounting on all new installations.



E-LED B HIGH MAST LIGHT 400W 480W



▼ DIMENSIONS

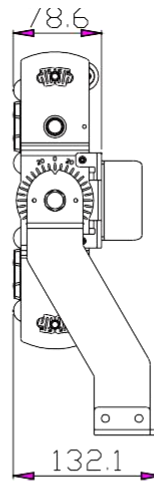
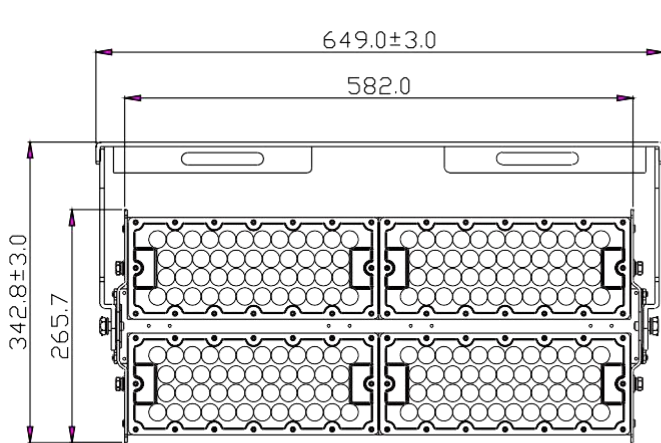

- ◀ Length: 25.55 in (649 mm)
- ▶ Height: 13.46 in (342 mm)
- ▼ Width: 5.2 in (132 mm)

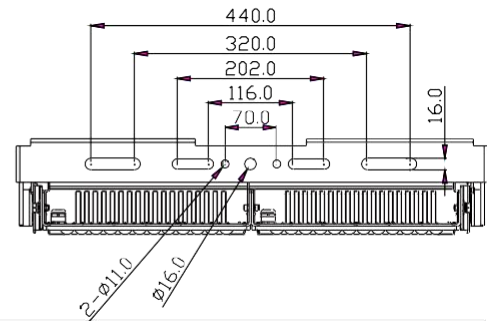

▼ PHOTOMETRICS

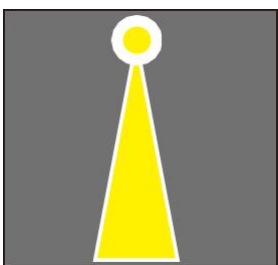

20°

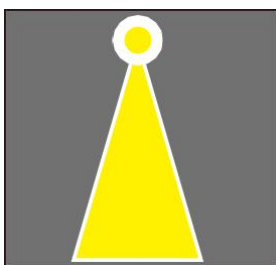

40°

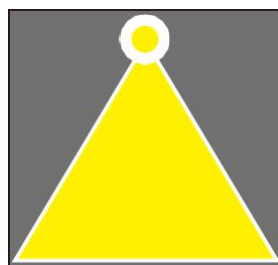

60°

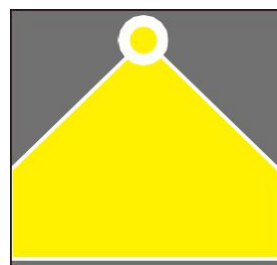

90°

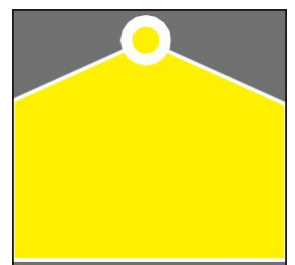

120°



All Applications

- Uniformity and light quality
- Light pollution and spillage
- Controls



Baseball, Softball

- High levels of illumination
- Lighted from all sides
- Reducing glare



Harbors, Wharfs

- Pole location (primarily sidelines)
- Pole quantity
- Number of fixtures per pole



Soccer, Lacrosse, Mixed Use

- Pole location
- Pole quantity
- Number of fixtures per pole



Basketball, Tennis

- Floodlight, or area-style fixtures
- Court configuration (grouping)
- Court access

- 1 ▶ Rotatable module
- 2 ▶ Replaceable optical lens
- 3 ▶ Protractor scale for easier aiming
- 4 ▶ Lengthened heavy duty mounting bracket allowing for 360° rotation
- 5 ▶ Salt spray resistant, corrosive resistant, processed with dedicated treatments on the heat sink and other components, these fixtures can withstand corrosive and salt intensive environments.



LED HIGH MAST AREA LIGHT SPECIFICATION SHEET



▶ OPTICAL SPECS

E-LED B 400W

E-LED B 480W

Efficiency:	Up to 150 Lm/W±3%	Up to 150 Lm/W±3%
Lumen:	60.000 Lumens	72.000 Lumens
Color Temp:	3000K / 4000K / 5000K / 5700K	
Light Source:	Lumileds 5050	
Beam Angle:	20° / 40° / 60° / 90° / 140*100° / Milky PC 120°	

▶ ELECTRICAL SPECS

Wattage:	400 Watt	480 Watt
Input Voltage:	100-277VAC	
Power Frequency:	50/60 Hz	
Driver:	2Pcs Meanwell ELG-150-48A	
Dimming:	Dimmable / Non-dimmable	

▶ OTHER DETAILS

Fixture Material:	Marine grade aluminum
IP Rating:	IP65 (TUV report available)
Module rotatable:	Module rotatable up & down 15°
Lifespan:	> 50,000 Hours
Dimensions:	25.55x14.25x5.2 in (649 x 342 x 132mm)
Certificates:	Salt Spray test





APPLICATION

- ▶ Outdoor lighting
- ▶ Security lighting
- ▶ Industrial lighting
- ▶ Sports field lighting
- ▶ Construction site lighting
- ▶ Highmast lighting

▼ ADJUSTABLE MOUNT

